

SBV11-8-O - Solenoid Bi-directional Valve

Bi-directional, normally open solenoid valve
60 L/min (15 USgpm) • 350 bar (5000 psi)

A

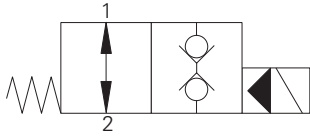

Operation

In the de-energized position the valve is open in both directions. A series of internal check valves allows full flow in both directions.

When the solenoid is energized the pilot poppet closes the pilot orifice causing the main poppet to close.

Features

Hardened and ground working parts. Lapped seat for low leakage. IP69K Tough coil compatibility. Continuously rated. Compact design with low pressure drop. 350 bar working pressure.

Sectional View

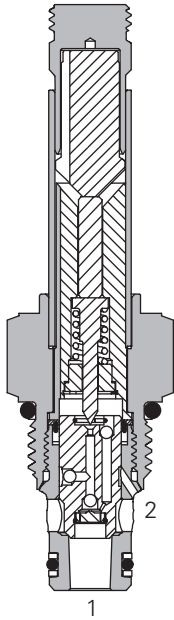

Performance Data

Ratings and Specifications

Performance data is typical with fluid at 21,8 cSt (105 SUS) and 49° C (120° F)

Typical application pressure (all ports)	350 bar (5000 psi)
Cartridge fatigue pressure (infinite life)	310 bar (4500 psi)
Rated flow	60 L/min (15 USgpm)
Internal leakage, port 1 to port 2 & port 2 to port 1	5 drops/min max @ 350 bar (5000 psi) when energized
Temperature range	-40° to 100° C (-40° to 212° F)
Coil duty	Continuous from 85% to 110% of nominal voltage
Cavity	C-8-2
Fluids	All general purpose hydraulics fluids such as: MIL-H-5606, SAE 10, SAE 20 etc.
Filtration	Cleanliness code 18/16/13
Housing material (standard)	Aluminum or steel
Weight cartridge only	0,12 kg (0.26 lbs)
Seal kit	02-160777 (Buna-N), 02-160778 (Viton®)

Viton is a registered trademark of E.I. DuPont

Description

This is a 2-way 2-position, high pressure bi-directional, pilot operated, normally open poppet type screw in cartridge valve. The valve is ideal for isolating and holding actuators in position.

Pressure Drop

Cartridge only

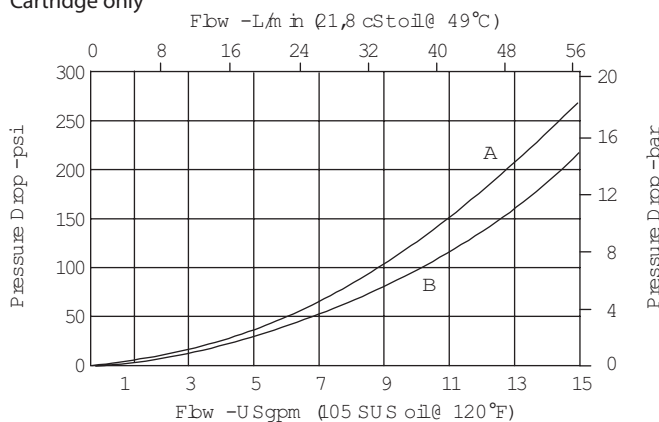

A - Port 1 to port 2

B - Port 2 to port 1

Where measurements are critical request certified drawings. We reserve the right to change specifications without notice.

SBV11-8-O - Solenoid Bi-directional Valve

Bi-directional, normally open solenoid valve
60 L/min (15 USgpm) • 350 bar (5000 psi)

Model Code

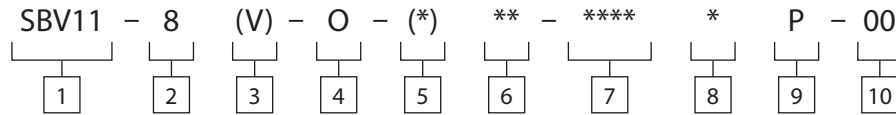

1 Function
SBV11 - Solenoid
bi-directional valve

2 Size
8 - 8 size

3 Seal Material
Blank - Buna-N
V - Viton*

4 Style
O - Normally open

5 Valve Housing Material
Blank - Cartridge only
A - Aluminum

6 Port Size

Code	Port Size	Housing Number	
		Aluminium	Steel
0	Cartridge only		
2G	1/4" BSPP	02-160727	02-160733
3G	3/8" BSPP	02-160728	02-160734
4T	SAE 4	02-160730	02-160736
6T	SAE 6	02-160731	02-160737
8T	SAE 8	02-160732	02-160738

See section J for housing details.

7 Voltage Rating

00 - No coil	24A - 24VAC
12D - 12VDC	115A - 115VAC
24D - 24VDC	230A - 230VAC
36D - 36VDC	12B - 12VDC/w diode*
	24B - 24VDC/w diode*

*Optional arc suppression diode.

8 Connector Types
Blank - No coil
G - ISO 4400 DIN 43650
Q - Spade terminals
W - Flying lead
N - Deutsch (DC only)
Y - Amp JR (DC only)
D - Metripack 150 male (DC only)
J - Metripack 280 male (DC only)

9 Coil Series
P - 8 Series, 23 W
For coil part numbers and dimensions see section C.

10 Special Features
00 - None
(Only required if valve has special features, omitted if "00")

Dimensions

mm (inch)

Torque cartridge in aluminum or steel housing 34-41 Nm (25-30 ft lbs)

Note: When solenoid valve is ordered as cartridge only, coil nut is included.

Cartridge Only

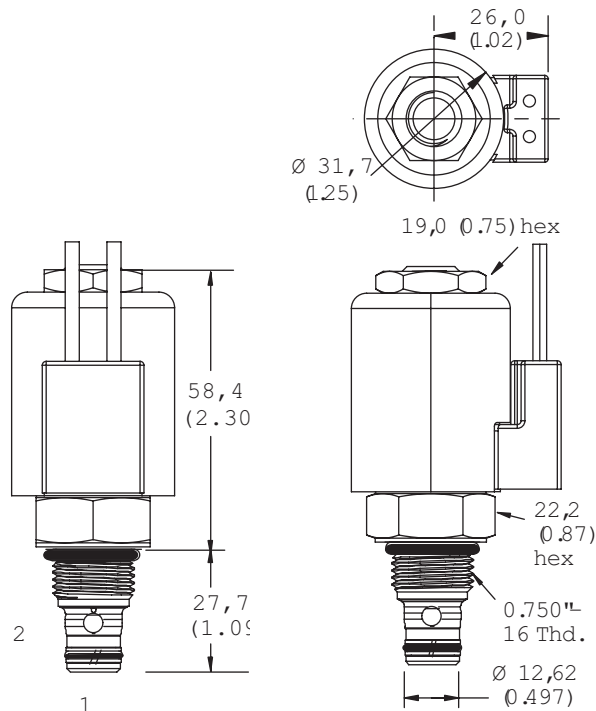

Installation Drawing (Steel)

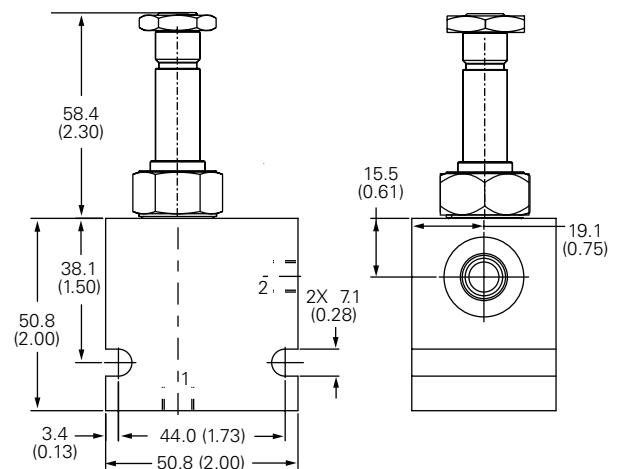

WARNING
Maintain 5-8 Nm (4-6 ft lbs) maximum torque on valve tube nut. Over tightening may cause valve failure.

WARNING
Aluminum housings can be used for pressures up to 210 bar (3000 psi). Steel housings must be used for operating pressures above 210 bar (3000 psi).